

F316L TRIM16

Fig No: WARREN-802HF-T

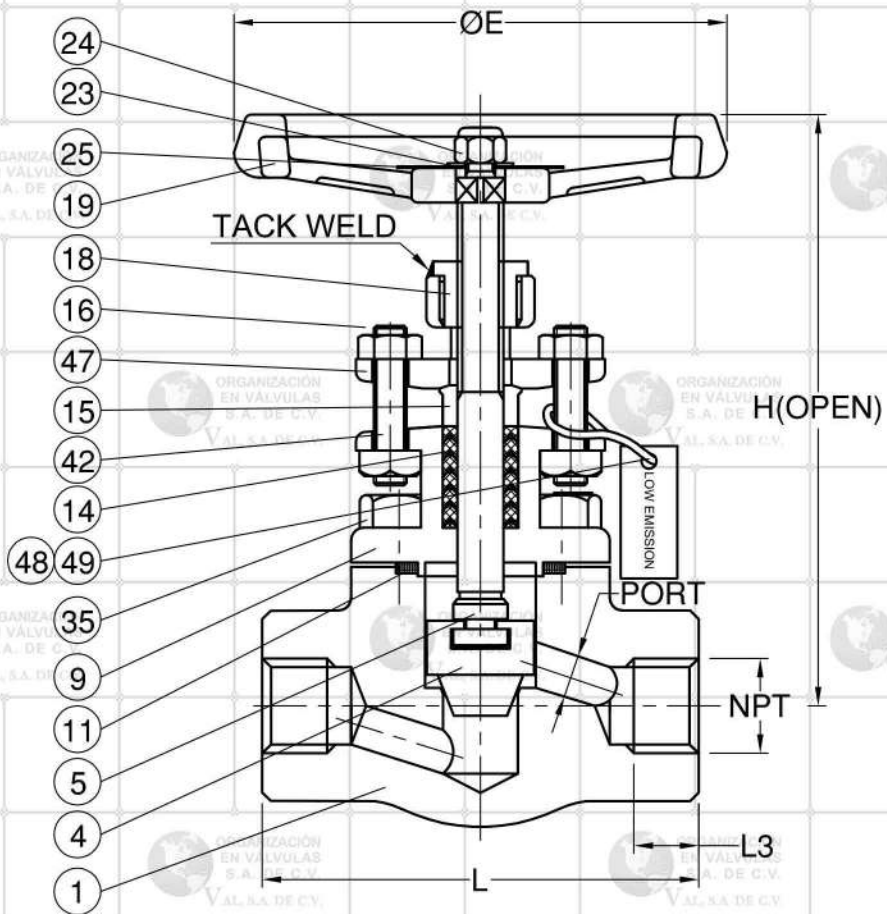

MATERIALS LIST

NO.	NAME	MATERIAL
1	BODY	ASTM A182 Gr.F316L+STL#6
4	DISC	ASTM A182 Gr.F316L+STL#6
5	STEM	ASTM A182 Gr.F316L
9	BONNET	ASTM A182 Gr.F316L
11	BODY SEAL	SPW 316+GRAPHITE
14	STEM PACKING	FLEXIBLE GRAPHITE
15	GLAND	ASTM A276 Gr.316L
16	GLAND NUT	ASTM A194 Gr.8MA
18	YOKE SLEEVE	ASTM A276 Gr.410
19	HANDWHEEL	ASTM A197
23	HANDLE WASHER	STAINLESS STEEL
24	H.W.NUT	ASTM A194 Gr.8MA
25	NAMEPLATE	SS304
35	BODY BOLT	ASTM A193 Gr.B8MA
42	GLAND BOLT	ASTM A193 Gr.B8MA
47	GLAND FLANGE	ASTM A182 Gr.F316L
48	LOW EMISSION	ALUMINIUM
49	CABLE TIE	NYLON

DIMENSIONS

unit:inch

SIZE	PORT	L	L3	ØE	H	NPT	Weight(lbs)	Torques(lbf.in)	CV(GPM)	
DN8	1/4"	0.24	3.11	0.37	3.74	6.61	1/4"	4.3	132.98	1.5
DN10	3/8"	0.24	3.11	0.41	3.74	6.61	3/8"	4.3	132.98	1.5
DN15	1/2"	0.39	3.11	0.54	3.74	6.61	1/2"	4.3	132.98	1.5
DN20	3/4"	0.51	3.62	0.55	3.74	6.69	3/4"	4.6	221.63	3.8
DN25	1"	0.69	4.37	0.69	4.72	8.07	1"	8.0	336.87	6.8
DN40	1-1/2"	1.13	5.51	0.72	5.91	9.25	1-1/2"	12.5	620.55	14.3
DN50	2"	1.44	6.77	0.76	6.69	11.10	2"	20.2	753.53	25

APPLICABLE STANDARDS:
 Globe Valve:API 602,NACE MR 01-75
 Shell Wall Thickness:API 602
 Flow passageway:API 602
 Stem diameter:API 602
 Thread:ASME B1.20.1
 Inspection Per API 598
LOW EMISSIONS PER ANSI/ISA 93.00.01-1999
100 PPM OR LESS



	APPROVED BY.	CHECK BY.	DRAWN BY.	DRAWINGNO.	MATERIAL	UNIT	DESCRIPTION
SIGN	AMOS CHEN	XIAOFENG JIN	HUIJIAN XIANG	WARREN-802HF-T	MATERIALS LIST	inch	FORGED STEEL GLOBE VALVES, THREADED END, ANSI CLASS 800
DATE	06/04/2012	06/04/2012	06/04/2012	REVISION 01	SCALE	FREE	