

BODY MARK - For 2-1/2" , 3"

2 1/2
CF8M

200

WARREN



Fig No:

WARREN-223

MATERIAL LIST

NO.	PART NAME	MATERIAL	Q'TY
		STAINLESS STEEL	
1	BODY	ASTM A351-CF8M	1
2	CAP	ASTM A351-CF8M	1
3	HINGE PIN	AISI SS316	1
4	PLUG	AISI SS316	1
5	DISC	ASTM A351-CF8M	1
6	GASKET	PTFE	1
7	PLUG SEAL	PTFE	1
8	NAME PLATE	ALUMINUM	1

2-1/2" , 3" For T-PATTEM

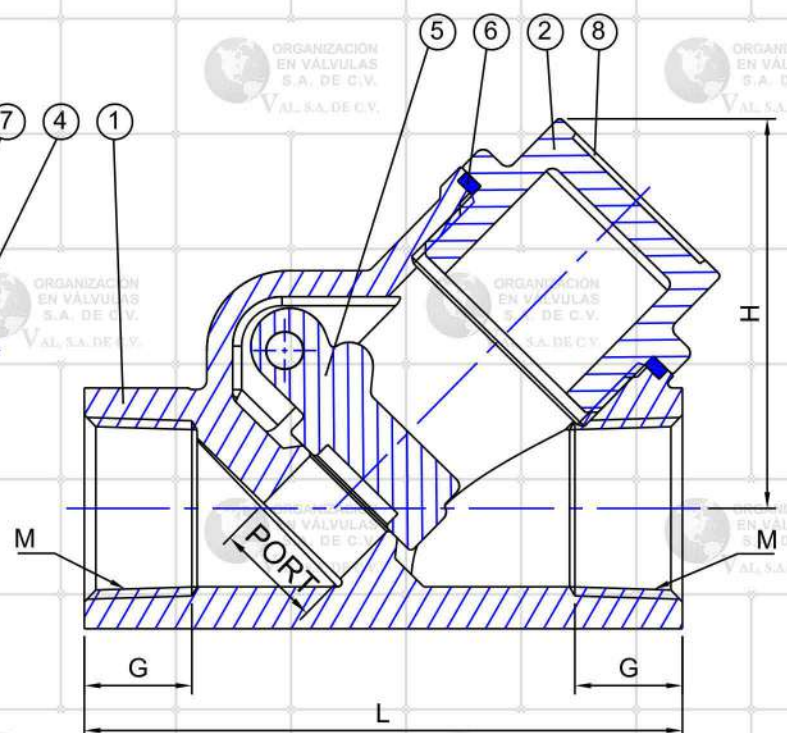
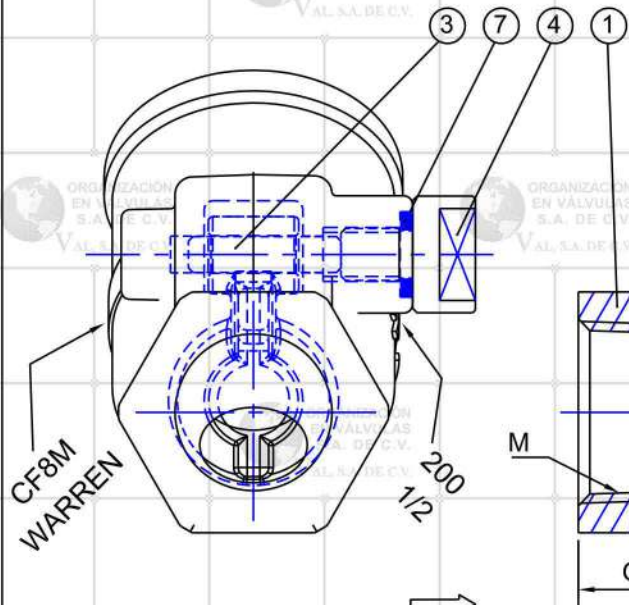

DIMENSIONS

unit:inch

SIZE	PORT	L	G	H	M	CV(GPM)	CRACKING PRESSURE(PSI)	WEIGHT(LBS)	
DN15	1/2"	0.47	2.63	0.47	1.71	NPT	4	0.0586	0.70
DN20	3/4"	0.82	3.32	0.63	2.05	NPT	13	0.0633	1.19
DN25	1"	0.94	3.82	0.67	2.28	NPT	18	0.0681	1.57
DN32	1-1/4"	1.22	4.49	0.71	2.72	NPT	30	0.0811	2.56
DN40	1-1/2"	1.54	5.11	0.76	3.07	NPT	49	0.0658	3.62
DN50	2"	2.03	6.02	0.94	3.66	NPT	89	0.0601	5.07
DN65	2-1/2"	2.56	6.12	0.94	3.54	NPT	146	0.0596	8.86
DN80	3"	2.99	7.28	1.20	3.88	NPT	201	0.0593	12.48

BODY MARK - For 1/2" , 2"

TEST PRESSURE:

Shell (by Water), 300 Psig
Seat (by Air), 80 Psig

APPLICABLE STANDARDS:

NPT Threads To ANSI B 1.20.1



APPROVED BY.	CHECK BY.	DRAWN BY.	DRAWINGNO.	MATERIAL	UNIT	DESCRIPTION
SIGN	CHANG	PETER CHEN	Ann	WARREN-223	ASTM A351-CF8M	INCH
DATE	11/14/2012	11/14/2012	11/14/2012	REVISION	01	SCALE
						FREE
						DESCRIPTION
						STAINLESS STEEL CHECK VALVES, THREADED END, 200 WOG