

BODY MARK

1/2
200
CF8M
WARREN

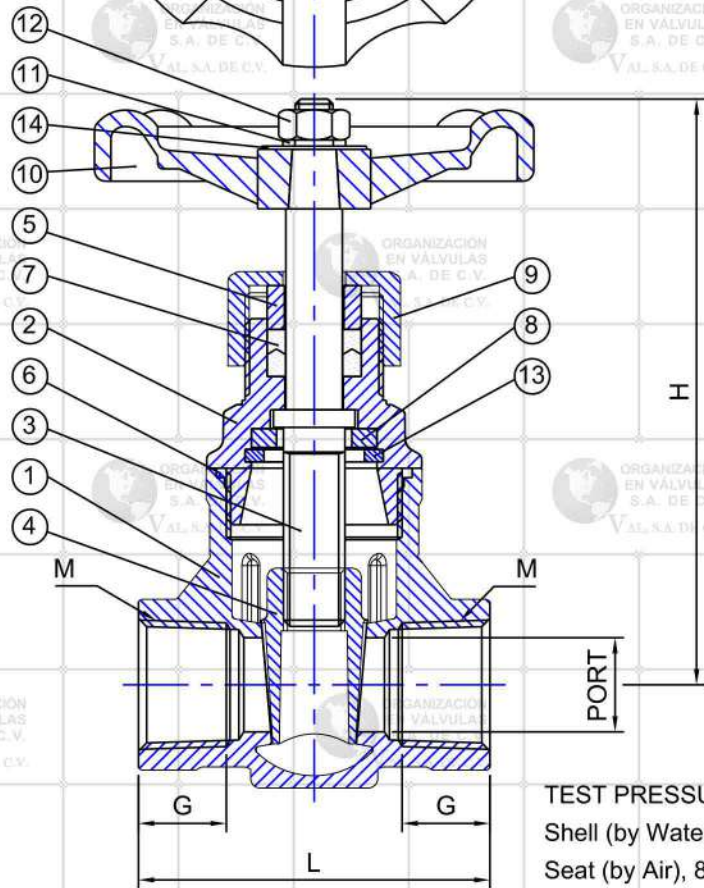

TEST PRESSURE:
Shell (by Water), 300 Psig
Seat (by Air), 80 Psig

APPLICABLE STANDARDS:
NPT Threads To ANSI B 1.20.1

Fig No:

WARREN-221

MATERIAL LIST

NO.	PART NAME	MATERIAL	Q'TY
		STAINLESS STEEL	
1	BODY	ASTM A351-CF8M	1
2	CAP	ASTM A351-CF8M	1
3	STEM	AISI SS316	1
4	DISC	ASTM A351-CF8M	1
5	GLAND	AISI SS316	1
6	GASKET	PTFE	1
7	PACKING	PTFE	1SET
8	WASHER (2)	AISI SS304	1
9	GLAND NUT	ASTM A351-CF8M	1
10	HANDLE WHEEL	ADC 12	1
11	WASHER (1)	AISI SS304	1
12	HANDLE WHEEL NUT	AISI SS304	1
13	C-SNAP RING	AISI SS301	1
14	NAME PLATE	ALUMINUM	1

DIMENSIONS

unit:inch

SIZE	PORT	L	G	H	W	M	CV(GPM)	TORQUE(LBF-IN)	WEIGHT(LBS)
DN15	1/2"	0.59	2.20	0.55	3.71	2.76	NPT 22	221.28	0.93
DN20	3/4"	0.79	2.38	0.67	3.94	2.76	NPT 42	221.28	1.23
DN25	1"	0.98	2.68	0.71	4.45	3.15	NPT 67	265.53	1.72
DN32	1-1/4"	1.26	2.99	0.75	5.06	3.15	NPT 113	292.08	2.51
DN40	1-1/2"	1.57	3.15	0.75	6.03	3.94	NPT 182	371.74	3.40
DN50	2"	1.97	3.66	0.91	6.68	3.94	NPT 298	442.55	5.07
DN65	2-1/2"	2.56	4.59	1.10	8.10	4.53	NPT 516	566.46	11.5
DN80	3"	3.15	5.12	1.26	8.98	4.53	NPT 802	663.83	15.2



APPROVED BY.	CHECK BY.	DRAWN BY.	DRAWINGNO.	MATERIAL	UNIT	DESCRIPTION
SIGN	CHANG	PETER CHEN	WARREN-221	ASTM A351-CF8M	INCH	STAINLESS STEEL GATE VALVES, THREADED END, 200 WOG
DATE	05/02/2012	05/02/2012	REVISION	SCALE	FREE	